

Compact, Low-Cost Direction-Finding Using Time to Digital Converters

Maria Kelly
ESL Defence Ltd,
16 Compass Point, Ensign Way
Hamble, Southampton, SO31 4RA

Abstract

Previous work within an EMRS DTC funded project focussed on investigating a method of implementing TDOA for low-cost UAV or land vehicle applications, using a Commercial Off The Shelf (COTS) Time-to-Digital Converter (TDC). The technology demonstrator was designed and constructed, adopting a short baseline of only 2m, and tested briefly on commercial emitters. This year's project work was based on the use of the existing technology demonstrator and the LabView software written to log and process the data measured. The project verified further the performance capabilities of the technology demonstrator against realistic military emitters through the following two routes; measurement of typical threat emitters and data analysis of the measured data. The bearing calculations produced after post-processing indicate that in a single emitter environment the TDOA kit reported a bearing of 2.84° for an actual emitter bearing of 0° . In addition to providing a bearing, several other emitter-identifying parameters are easily extracted from the measured data, such as pulse widths, pulse rise times, inter-burst periods and the number of pulses per burst.

Keywords: Direction Finding, Time-to-Digital Converters, TDOA, UAV

Introduction

For low-cost Unmanned Airborne Vehicle (UAV) or land vehicle applications, Time Difference of Arrival (TDOA) is considered the most appropriate direction-finding (DF) technique because of its inherent simplicity and robustness (used for example in the US Guardrail Common Sensor). Assuming a simple configuration, as shown in Figure 1, with two antennas separated by the wingspan of a UAV, the Angle of Arrival (AoA) of pulsed radar emissions from a threat emitter can be determined. However, due to the small antenna separation distances available on such platforms (Shadow 200 wingspan is 3.4m, for example) high resolution is required in the timing measurement used to determine an accurate AoA. For example, to obtain an RMS AoA error of 2° on boresight, using a 2m baseline, requires a theoretical TDOA RMS resolution of 230ps [1].

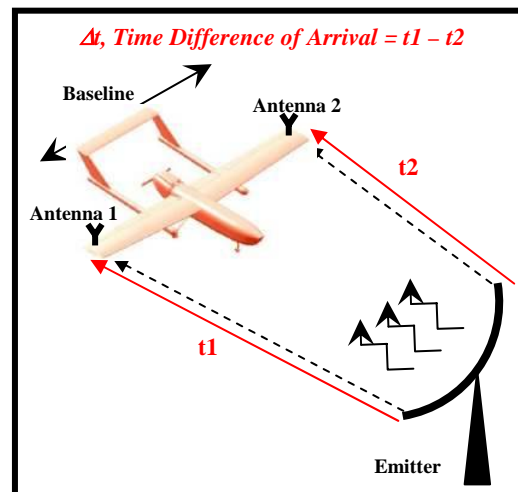

Figure 1 TDOA Configuration on a UAV

A technology demonstrator has been constructed [1], with a system configuration shown in Figure 2. At the core of the TDOA structure is a Time-to-Digital Converter (TDC) [2-4] that measures the relative timing of pulse edges with two operating modes. The high-resolution mode has a timing accuracy of 60ps resolution,

whilst the low-resolution mode has a timing resolution of 120ps. Due to the two-antenna channel configuration the low-resolution mode was used, but even with a resolution of 120ps a 1° error on boresight is theoretically achievable.

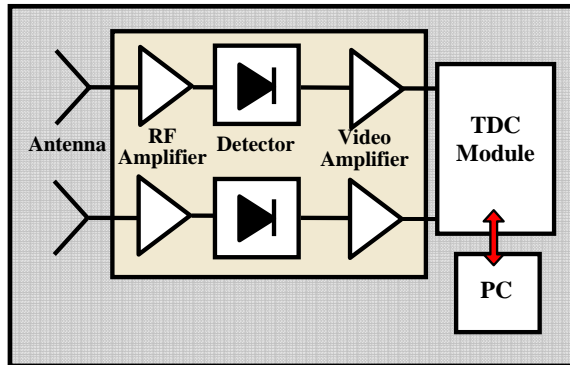

Figure 2 TDOA System Configuration

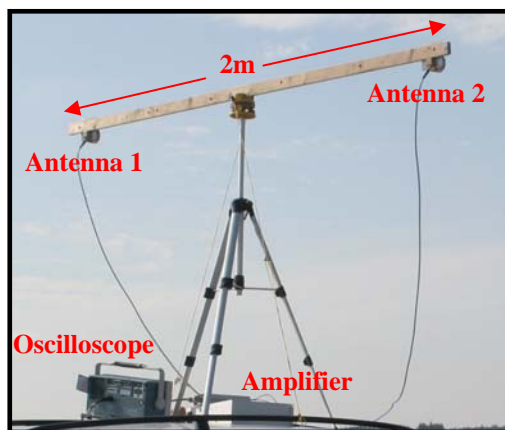

Figure 3 Experimental TDOA System

Experimental Equipment

The performance of a short baseline TDOA DF system using TDCs has now been assessed theoretically, by simulation and by field trials involving representative threat emitters [1-4]. Two wideband spiral antennas (2-18GHz) were mounted onto a 2m support to feed received signals into a simple square-law detector and RF preamplifier. The frequency response of the detector/amplifier is 2-18GHz, and has a video bandwidth of 20MHz. The two signal outputs from the amplifier feed into two channels of the ACAM TDC, and from there into a PC, via an ACAM PC data

card. An indicative cost breakdown of the TDOA system, when construction, test, integration and calibration is included, could produce a system cost in the region of £10,000. A photograph of the equipment in use during a field trial is shown in Figure 3.

Data Acquisition and Processing

Emissions from pulsed radars are typically in the form shown in Figure 4. A preset number of pulses are grouped into a series of bursts, separated by a distinct inter-burst period. Some radar operate complex modes where several different pulse-per-burst levels are used, separated by varying inter-burst periods, sometimes using multiple operating frequencies.

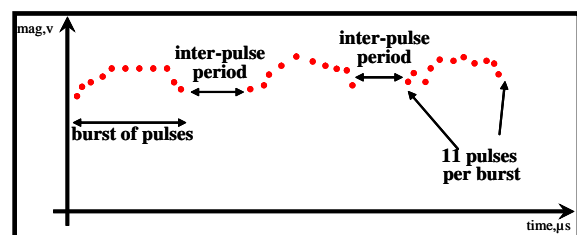
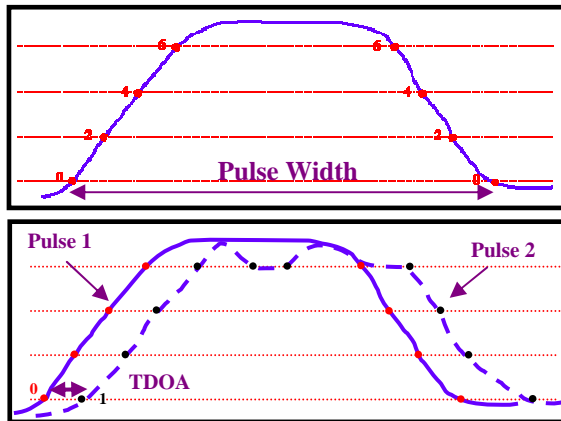

Figure 4 Typical Received Pulsed Radar Output

Bespoke data acquisition and processing software has been written by ESL, in LabView, to determine the bearing of a pulsed radar from the difference in arrival time of a pulse arriving at two spatially separated antennas. However, trial data analysis has shown that parameters shown in Figure 4 can also be extracted. When a single pulse from an emitter is received by the two TDOA antennas, the TDC module records the arrival time of the pulse at each antenna. The TDC unit also tags each pulse rising and falling edge with user-defined threshold levels – shown as 0-7 in Figure 5. Once each pulse has been tagged in such a way, the LabView data acquisition records each pulse arrival time, and the time at each threshold level crossing.

From this logged data, processing is carried out, again with LabView, to extract the bearing of the pulsed emitter for each pulse

received over a few seconds of data reception. Parameters that can also be extracted from the received data are shown in Figure 5; pulse width, TDOA, pulse rise time. The LabView data processing output reports the number of pulses per burst of a set of measured data, the inter-burst period, the pulse width and the bearing, along with an indication of variation of the bearing (in the form of standard deviation).



$$\text{Bearing, } \theta = \text{Arc sin} \left(\frac{\text{TDOA} \cdot c}{\text{Baseline}} \right)$$

Figure 5 Pulse Threshold, Width, Bearing and TDOA Definition

Trial Results

Trials were performed at two off-site locations, RAF Spadeadam and Dstl Portsdown. These locations were selected because they had a selection of representative pulsed radar and threat emitters against which to test the TDOA equipment. At RAF Spadeadam access was possible - line of sight at a range of about 100m - to an air traffic control Watchman radar, and a surface to air tracking radar. At Portsdown access was possible - line of sight at a range of 600-1400m - to two naval radars. The operational pulse width and frequency of only one radar, Watchman, is in the public domain. It operates at S-band with dual pulse widths of 400ns and 20µs. Data from the other three radars will not be presented here due to security restrictions.

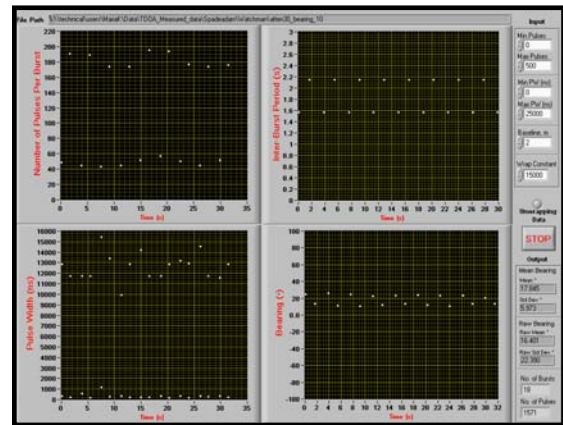

Watchman: Measurement Angle +10°

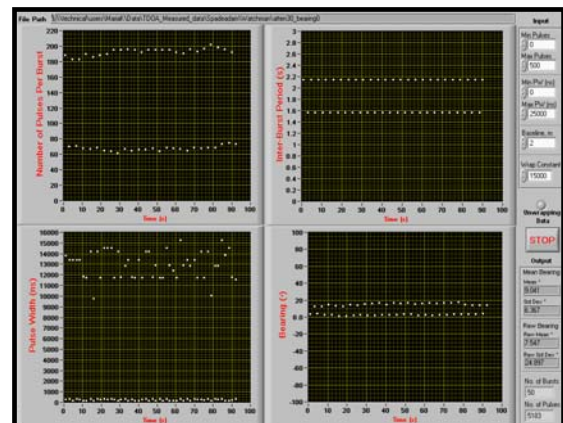

Watchman: Measurement Angle 0°

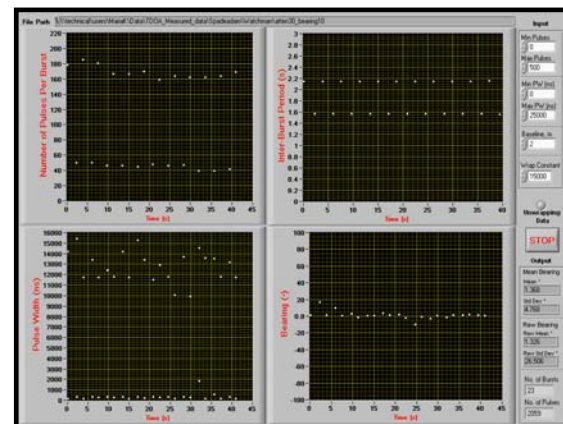

Watchman: Measurement Angle -10°

Figure 6 Watchman Field Trial Data

For each radar, several different measurements were made. The first positioned the baseline so that it was parallel to the radar being measured, i.e. the bearing was 0°. The second measurement rotated the baseline anti-clockwise, so that there was a small angular difference, 10°, from the boresight measurement. The third measurement rotated the baseline clockwise, also by 10°. Additional angular

measurements were made, depending on the weather conditions and suitability of the rotation. By carrying out measurements in at least three different positions a corresponding angular change should be reported in the TDOA bearing; assuming this occurs it will endorse the validity of the field trial measurements and reported TDOA bearing. TDOA outputs from measurements at $+10^\circ$, 0° and -10° are shown in Figure 6.

Measurement Summary

Measured Angle	Reported Angle (Mean)	Diff	σ
$+10^\circ$	17.85°	7.85°	5.97
0°	9.04°	9.04°	6.36
-10°	1.37°	11.37°	4.77

Table 1 Watchman Measurement Summary

Table 1 presents a summary of three of the Watchman measurement positions. For each of the three positions there is a difference between the expected bearing and the reported bearing of around $+10^\circ$, with a consistent standard deviation of around 5. Whilst the consistency of reporting is encouraging, a $+10^\circ$ difference is not acceptable if the TDOA model is to be confirmed to be suitable for practical implementation.

A further examination of the three measurement outputs revealed that in each plot there are two distinct pulse-per-burst values (60 and 180), two distinct inter-burst periods (1.6s and 2.2s) and two distinct pulse widths (400ns and $13\mu\text{s} - 13\mu\text{s}$ rather than the expected $20\mu\text{s}$, due to wrapping issues[3]). This suggested that two different modes of operation were being used by Watchman, behaviour that is documented as being typical for Watchman radars. In an attempt to isolate a single mode, the data processing interface was used to view the parameters for the largest pulse-per-burst

count only, shown in Figure 7, for the 0° data.

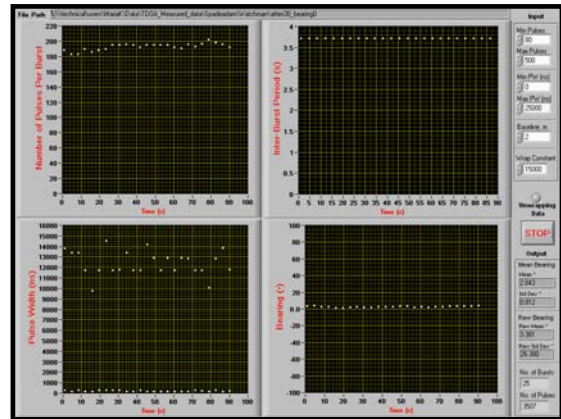

Figure 7 Isolation of First Watchman Mode - 0°

As can be seen, with a single pulse-per-burst level, both pulse widths are still reported and the bearing is now calculated to have a mean of 2.84° , and standard deviation of 0.81, for an actual bearing of 0° . If the second mode is isolated in the same way, viewing the lower pulse-per-burst level only as shown in Figure 8, a similar trend is apparent. The bearing plot is once again far more consistent than in Figure 6, although reporting with a mean of 15.24° and a standard deviation of 1.44.

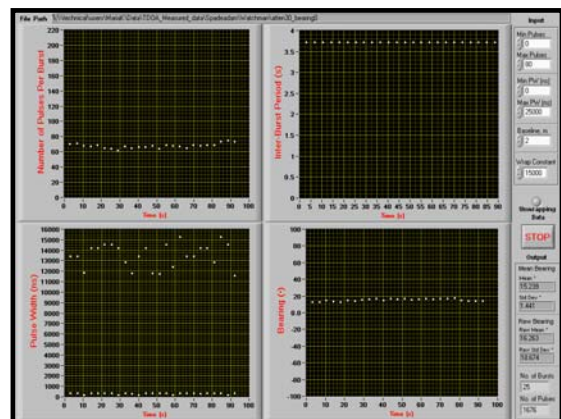

Figure 8 Isolation of Second Watchman Mode - 0°

The 15° bearing mean in the second mode is contributing significantly to the 10° offset when viewing both operational modes. The reason for this 15° offset is at present unconfirmed, however, a few causes are likely. There is clearly a difference in calculated bearing between mode one and mode two. The most

probable difference between the two modes is the operational frequency. The operational bandwidth of the TDOA equipment is 2-18GHz, with a roll-off in performance at the upper and lower ends of the frequency range. Unfortunately, at least two of the measured radar, including Watchman, operate around or just below 2GHz. If one receive channel (antenna/detector/amplifier) performs differently than the other receive channel at this low/out of band frequency then it could contribute to a difference in the TDOA, resulting in as much as a 1-2° difference in the final bearing calculation. In addition, if a gain mismatch is present between the two receive channels, say 1dB, then this could contribute as much as a 5° difference to the final bearing calculation [1].

Conclusions

The outdoor trials provided an excellent opportunity to test the capabilities of the hardware and software of the TDOA system

References

1. James, GE, “*New Technologies For Low-Cost Direction Finding and ESM: Final Report Year 2*”, R/04/008, March 2005
2. James, GE, “*The Application of Time to Digital Converters to ESM Systems*” 1st EMRS DTC Technical Conference, Edinburgh, 2004
3. James, GE, “*The Practical Implementation of DF Systems Using Time-to-Digital Converters*” 2nd EMRS DTC Technical Conference, Edinburgh, 2005
4. Acam Messelectronic GMBH, www.acam.de
5. Kelly, M, “*New Technologies For Low-Cost Direction Finding and ESM: Final Report Year 3*”, R/05/002, March 2006

in a non-laboratory environment. The kit recorded emissions in single and multiple emitter settings, all during poor weather conditions. The bearing calculations show that in a single emitter environment, such as with the Watchman radar, the calculated bearing differed from the actual bearing by less than 3°. This figure worsens as additional operational modes, probably emitted at low/out of band frequencies, are measured, and in multi-emitter situations.

However, the post-processed data from the field trials indicates that in addition to a bearing calculation, the TDOA system can record several, additional, valuable radar parameters, such as pulse-per-burst levels, pulse widths and inter-burst timings. All of these parameters can be used to distinguish, and perhaps even classify, emitters in the field. This existing capability and the addition of a compact Instantaneous Frequency Measurement (IFM) would result in extremely effective low-cost operational ESM system.

Acknowledgements

The work reported in this paper was funded by the Electro-Magnetic Remote Sensing (EMRS) Defence Technology Centre, established by the UK Ministry of Defence and run by a consortium of SELEX Sensors and Airborne Systems, Thales Defence, Roke Manor Research and Filtronic.