

Microwave Frequency Selective Limiters

Padisan Phudpong and Ian C. Hunter

Institute of Microwaves and Photonics, School of Electronic and Electrical Engineering,
University of Leeds, Leeds, LS2 9JT, UK

Abstract

This paper describes the design of frequency-selective limiting circuits based on nonlinear matched reflection-mode bandstop resonators. This type of Frequency Selective Limiters achieves fast switching, high-level of power limiting, and flexible channel bandwidth. Initial measured results for a first-order device indicate 0 dBm limiting threshold, 32 dB limiting level, 2 dB insertion loss, and 200 MHz limiting bandwidth. The prototype has also been tested for intermodulation distortions and response time. In addition, a third degree device has been designed. Simulated results show an excellent highly selective bandstop performance at high powers with a near all-pass response at low signal powers. This is the first time that such a multi-pole matched Frequency Selective Limiter has been reported.

Keywords: Bandstop filters, limiting, microstrip resonators, microwave limiters, nonlinear filters.

Introduction to Frequency Selective Limiters

Limiters are often used at the front-end of microwave receivers to protect sensitive circuitry against large interfering signals. Some conventional limiters make use of shunt PIN diodes placed before the receivers. However, PIN limiters cannot discriminate the received signals in terms of frequency. They respond to the total rf power, attenuating all signals when the accumulative powers exceed the limiting threshold. Thus limiting the magnitude of large signals also attenuates the wanted small signals, with a consequent reduction in sensitivity.

. The higher the rf power, the higher the stopband attenuation. The resulting output spectrum contains signals of relatively equal amplitudes, and low dynamic range.

In order to improve the receiver sensitivity, a Frequency Selective Limiter (FSL) is used to limit signals at individual frequencies independently. One FSL channel compresses only a large signal at one particular frequency, but passes signals of small amplitudes or at other frequencies without attenuation. The basic operation of a wideband FSL is illustrated in Figure 1. In general, microwave receivers operate in a dense signal and wide dynamic range environment. The FSL is designed to provide attenuation of the signals above a set signals. It has variable attenuation controlled by the level of rf input power

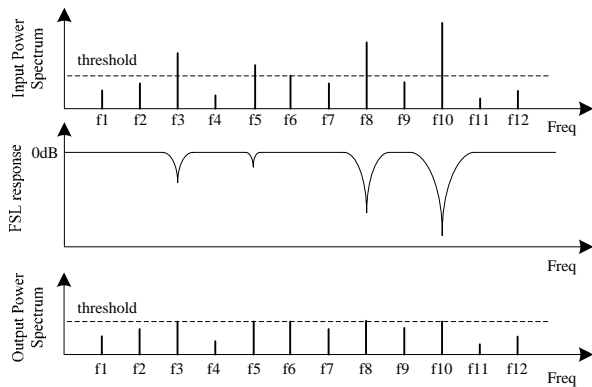

Figure 1: The basic operation of a Frequency Selective Limiter.

A number of ferrite-based FSLs have been reported [1]-[3], where the nonlinear characteristic of ferrite materials (e.g. YIG) is utilised. At low power levels, the signals coupled into a YIG film produce linear, low-loss outputs. At high power levels, the nonlinear excitation of the magnetic spin wave in the YIG film produces the limiting effect, which results in large signals being dissipated inside the ferrite material. This nonlinear coupling takes place over a narrow bandwidth depending on the ferrite material used, e.g. 20 MHz for YIG. However, the use of ferrite causes a spike leakage problem, and low level of limiting per one limiter section.

Another FSL approach is proposed by Christen Rauscher [4]. This technique uses rf front end channelisation. The rf signals are demultiplexed into small channels. Each channel is limited individually by conventional limiting amplifiers. Then signals after limiting are combined by multiplexers. This is a straightforward method of FSL. The limiting threshold can be determined by the limiting amplifiers. However, the design of multiplexers and demultiplexers can be complicated since highly selective filters are required for narrow channels.

In this paper a new method of frequency selective limiting is presented. It consists of a passive bandstop resonator loaded with a

nonlinear semi-conductor device, schottky diode. This circuit is termed a *Bandstop Limiter*. Its key concept is based on the fact that the diode's resistance can be controlled by the input rf power level. Therefore, its response can vary from all-pass to bandstop depending on the rf power. However, the Bandstop Limiter suffers from losses imposed by the microstrip structure and the loaded diodes. For high-Q networks, the Bandstop Limiters are incorporated in a reflection mode configuration to provide a theoretically perfect-notched response. This technique achieves low insertion loss, flexible channel bandwidth and centre frequency, low spike leakage, and high level of power limiting.

Fundamentals of the Bandstop Limiter

The Bandstop Limiter makes use of a nonlinear bandstop filter. This technique employs a bandstop resonator loaded with a diode. The resonator is designed to have a narrow-band bandstop response at a limiting frequency. The diode enables the stopband attenuation of the resonator to vary with the rf power, and hence determines the limiting threshold of the Bandstop Limiter. The diode used in the circuit is a GaAs Beamlead Schottky diode. Due to the physical structure of beamlead devices and material properties of GaAs, the chosen diode has low package parasitics, junction capacitance, and series resistance, suitable for high-frequency, high-Q applications. Moreover, the schottky diode has small variation in the junction capacitance between ON and OFF states due to no charge being stored in the Schottky barrier. Consequently, there is only a minor shift in the centre frequency when limiting wide dynamic range signals.

A simple Bandstop Limiter can be constructed as shown in Figure 2. The rf choke is used to bias the diode. The bias current is derived from the diode rectification of the rf signal. The rf choke

presents a high impedance to rf signals and creates a DC loop allowing the bias current to flow.

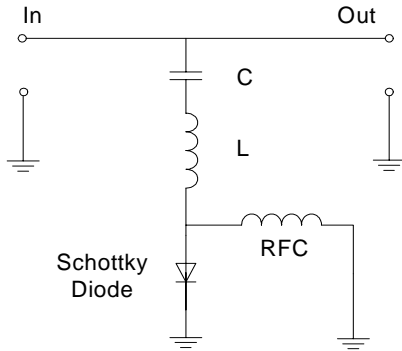

Figure 2: Lumped LC Bandstop Limiter.

The operation of the Bandstop Limiter can be divided into two modes, all-pass and bandstop. The all-pass mode occurs when the inputs are below threshold, or above threshold but outside the resonator bandwidth. For small signals, the voltage across the diode is less than the threshold voltage, leading to no bias-current flow. The diode is in non-conduction state where it exhibits very high impedance, and hence presents an open circuit. The small signals then pass the Bandstop Limiter without attenuation. The power level of signals that lie outside the resonator bandwidth might be large enough to turn on the diode. However, the series resonator presents very high impedance to the signals at frequencies other than the resonant frequency. Therefore, the Bandstop Limiter passes them as it does the small signals.

The second mode of operation is the bandstop mode. This mode occurs when a large signal at the resonant frequency is input to the circuit. At the resonant frequency, the series resonator has theoretically zero impedance. The stopband attenuation of the Bandstop Limiter depends on diode resistance, which is controlled by the rf power. At high power levels the diode resistance is low, the total Q of the resonator is high and the stopband attenuation is high. At low power levels the

diode resistance is high, and consequently the stopband attenuation is low.

First Order Bandstop Limiter

At high frequencies it is more convenient to realise the Bandstop Limiter in microstrip. However, the lossy nature of microstrip makes it difficult to achieve a high Q. Moreover, the incorporated diode also deteriorates the total Q of the Bandstop Limiter. The circuit Q of the Bandstop Limiter can be improved by applying the perfect-notched concept [5,6]. Based on a reflection mode filter, this concept makes use of two identical lossy resonators coupled to a 3-dB 90° hybrid coupler with correct coupling factors. At the centre frequency, the incident signals are critically coupled to the resonators and absorbed in the resistive part of the resonators leaving no reflected signals to the output, then achieving a theoretically infinite attenuation.

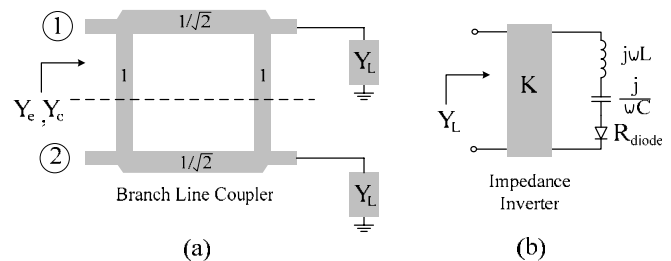

Figure 3: (a) a reflection mode filter consisting of a branch line coupler and two identical resonators; (b) a lossy resonator circuit.

Considering the unloaded branch line coupler, its even and odd-mode transmission matrix can be written as;

$$\begin{bmatrix} A & B \\ C & D \end{bmatrix}_e = \frac{1}{\sqrt{2}} \begin{bmatrix} -1 & j \\ j & -1 \end{bmatrix} \quad (1)$$

$$\begin{bmatrix} A & B \\ C & D \end{bmatrix}_o = \frac{1}{\sqrt{2}} \begin{bmatrix} 1 & j \\ j & 1 \end{bmatrix} \quad (2)$$

Considering Y_e and Y_o when Y_L is connected to each of the output ports of the coupler as in Figure 3(a),

$$Y_e = \frac{DY_L + C}{BY_L + A} = \frac{j - Y_L}{jY_L - 1} \quad (3)$$

$$Y_o = \frac{jY_L - 1}{j - Y_L} = \frac{1}{Y_e} \quad (4)$$

For a symmetrical two-port network, the S-parameters are,

$$S_{11} = \frac{1 - Y_o Y_e}{(1 + Y_o)(1 + Y_e)} \quad (5)$$

$$S_{12} = \frac{Y_o - Y_e}{(1 + Y_o)(1 + Y_e)} \quad (6)$$

From (4), $Y_o = 1/Y_e$, and hence $S_{11} = 0$. The network is then perfectly matched, and

$$S_{12} = \frac{Y_o - Y_e}{(1 + Y_o)(1 + Y_e)} = \frac{(1 - Y_L)(j + 1)}{(1 + Y_L)(j - 1)} \quad (7)$$

For a first degree limiter, Y_L is implemented using the network shown in Figure 3(b). Assuming $K=1$ of the impedance inverter,

$$Y_L = R_d + j\omega L - \frac{j}{\omega C} \quad (8)$$

where R_d is a diode resistance.

Hence,

$$|S_{12}(j\omega)|^2 = \frac{(1 - R_d)^2 + \left(\omega L - \frac{1}{\omega C}\right)^2}{(1 + R_d)^2 + \left(\omega L - \frac{1}{\omega C}\right)^2} \quad (9)$$

For *low* rf power, R_d is high, so (9) is reduced to,

$$|S_{12}(j\omega)|^2 \approx 1, \quad (10)$$

which is an *all-pass* response.

For *high* rf power, R_d is low. Assuming $R_d = 1$,

$$|S_{12}(j\omega)|^2 = \frac{1}{1 + \frac{4}{\left(\omega L - \frac{1}{\omega C}\right)^2}}, \quad (11)$$

which gives the *bandstop response* with the maximum attenuation at the centre frequency.

The layout of a single-resonator microstrip Bandstop Limiter is shown in Figure 4. It comprises a 3-dB 90° branch line coupler, quarterwave transformers as impedance inverters (K), and two identical bandstop resonators loaded with schottky diodes. The resonators are built using microstrip lumped components; where the capacitors are realised by interdigital capacitors, and the inductors by inductive short-circuited stubs. The schottky diodes are placed in series between these two components. This arrangement inherently provides DC blocks. The DC return paths are realised by quarterwave length short circuit stubs. The circuit was constructed on a substrate, with dielectric constant ϵ_r of 2.2, and a thickness of 0.787 mm.



Figure 4: Prototype of a single-resonator microstrip Bandstop Limiter.

The circuit was designed to give a resonant frequency of 2 GHz. The interdigital

capacitor had 3 fingers with 5 mm finger length, 0.2 mm finger width, and 0.2 mm finger gap. The inductive short-circuited stub is 1.1 mm wide and 17 mm long. The characteristic impedance of the coupler is $Z_0=50\Omega$, and $Z_0/\sqrt{2}=35.35\Omega$. The Beamlead Schottky Diode, MA4E2037, from M/A-com is used.

The measured results in Figure 5 show that the attenuation of the Bandstop Limiter was below 2 dB for the rf power levels less than 0 dBm. It gradually increases as the rf power level is increased. In this experiment, a maximum stopband attenuation of 32 dB was achieved at the rf power level of 15 dBm. The limiting bandwidth of the device was approximately 200 MHz.

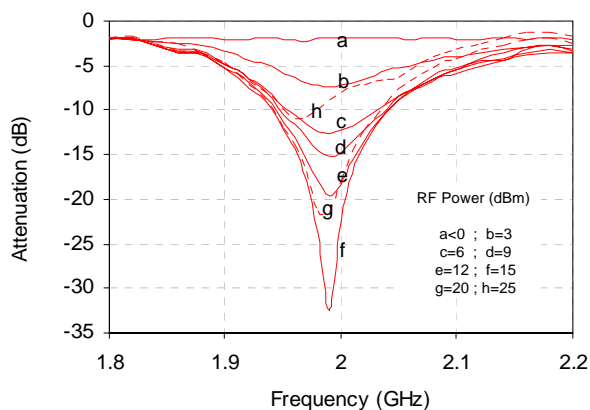

Figure 5: Measured results of a single-resonator Bandstop Limiter.

Intermodulation distortion is common for non-linear circuits. In Bandstop Limiters, the use of non-linear devices, schottky diodes, has resulted in the intermodulation products when two or more signals are input to the circuit. Shown in Figure 6 was the experiment in which two signals were input to the circuit; fundamental at 2 GHz, and interference at 1.98 GHz. The frequency separation was 20 MHz. Because the limiting bandwidth of the device was 200 MHz, the interference signal and the intermodulation products were generated within the resonator bandwidth.

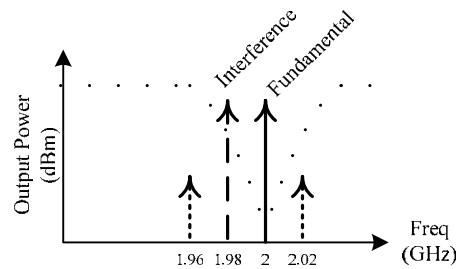

Figure 6: Intermodulation experiment.

In Figure 7, it is seen that when the input power is lower than the diode's threshold (diode OFF), the Bandstop Limiter has linear response, and the third order intermodulation product (IP3) is as low as the noise level. When the input power is higher than the threshold, 0 dBm, the diode is switched on. The Bandstop Limiter starts to compress the fundamental signal. At this ON state, the circuit is working non-linearly causing the IP3 to rise rapidly. From the experiment, the input third-order intercept point was measured at 17 dBm. More details of the intermodulation experiment can be found in [7].

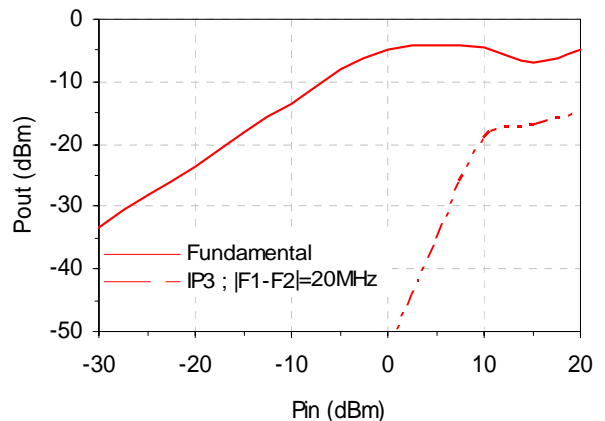

Figure 7: Power input versus power output of the Bandstop Limiter where the fundamental frequency is 2 GHz, and the interference signal having frequency separation of 20 MHz.

The deployment of a diode in the limiter circuit leads to a time delay before the circuit actually limits the rf signals. This time delay is crucial for the limiter since it determines the capability of limiting pulse signals. For narrow pulse receivers such as radar receivers, the fast response limiters

are needed. The experiment of the device's response time is shown in Figure 8. The pulse-modulated signals are input to the circuit with varied input power levels; from 0 dBm (limiting threshold) to 15 dBm. The response time of the limiter was measured at 10 nsec, which indicated the minimum pulse's width that can be detected by the receivers.

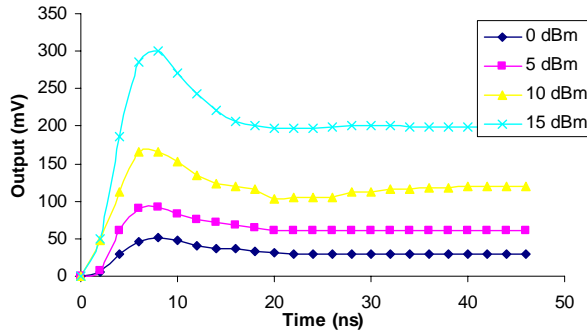

Figure 8: Response time of the Bandstop Limiters.

High-Order Bandstop Limiters

A single-resonator Bandstop Limiter has shown a limited channel bandwidth, and poor selectivity because of the moderate Q value of the single resonator. These drawbacks lead to interactions between adjacent frequency channels when each Bandstop Limiter is cascaded for wideband operations. An alternative technique utilises the concept of a reflection mode filter having a ladder network of resonators with non-uniform Q values as described in [8].

For the reflection mode filter, the transmission coefficient S_{12} of the overall device is determined by the reflection coefficient S_{11} of the resonators. The reflection coefficient of the ladder network that produces an equi-ripple bandstop response is,

$$S_{11}(p, \alpha) = \prod_{r=1}^n \left[\frac{(p\alpha - j \cos \theta_r)}{(p\alpha - j \cos(\cos^{-1}(\alpha) + \theta_r))} \right] \quad (12)$$

where;

$$\theta_r = \frac{r\pi}{(n+1)} \quad (13)$$

α is a constant which determines the ripple level,
 n is the order of the resonators.

Thus, the admittance of the ladder network is defined by;

$$Y(p, \alpha) = \frac{1 - S_{11}(p, \alpha)}{1 + S_{11}(p, \alpha)} \quad (14)$$

A third-order Bandstop Limiter is realised through a ladder network of resonators shown in Figure 9. The component values are synthesised from the admittance expression in (14). After that, two identical ladder networks of Figure 9 are connected to a branch line coupler. A complete third order reflection mode Bandstop Limiter is shown in Figure 10.

The simulated results in Figure 11 show that the response of the third order Bandstop Limiter varies with input rf powers. The maximum stopband attenuation is 34 dB for an rf power of 25 dBm. This high-order Bandstop Limiter achieved high selectivity, so high-resolution Frequency Selective Limiters could be obtained.

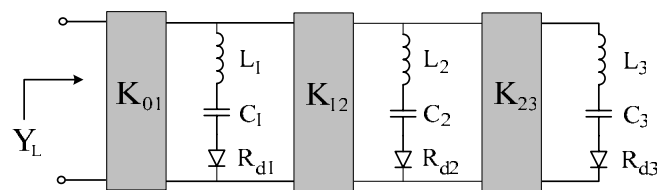

Figure 9: A ladder network of resonators giving third order equi-ripple bandstop response.

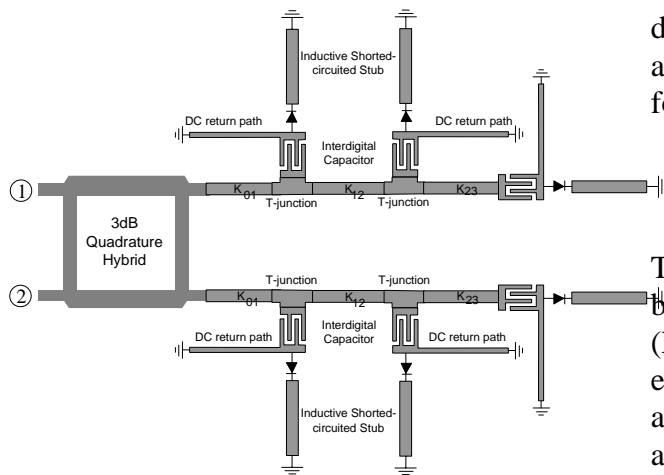

Figure 10: Microstrip circuits of a third order Bandstop Limiter.

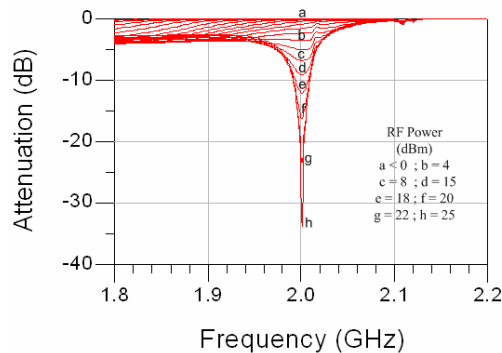

Figure 11: Simulation results of the third order Bandstop Limiter.

Conclusions and Future Works

The basic operation of the Bandstop Limiter was described by circuit analysis, simulations, and experiments. The prototype of a single-resonator Bandstop Limiter, based on a reflection mode filter, demonstrated high performance limiting characteristics applicable for Frequency Selective Limiting applications. The third-order version resulted in an improvement of selectivity and frequency resolution. Its prototype is now under construction. Since the Bandstop Limiter is matched ($S_{11} = 0$), it is feasible to cascade Bandstop Limiter modules for wideband operation. The circuit compresses large signals while maintaining the strength of small signals. A significant reduction in the signal dynamic range can be achieved. This type of

dynamic range compressor has potential application in Electronic Support Measures for Electronic Warfare Systems.

Acknowledgements

The work reported in this paper was funded by the Electro-Magnetic Remote Sensing (EMRS) Defence Technology Centre, established by the UK Ministry of Defence and run by a consortium SELEX Sensors and Airborne Systems, Thales Defence, Roke Manor Research and Filtronic.

References

- [1] J.D. Adam, and S.N. Stitzer, "Frequency selective limiters for high dynamic range microwave receivers," *IEEE Trans. MTT*, vol. 41, no. 12, pp. 2227-2231, 1993.
- [2] S.N. Stitzer, "Spike leakage and suppression in frequency selective limiters," *IEEE MTT-S Int. Microwave Symp. Dig.*, vol. 2, pp. 901-904, 2000.
- [3] A.J. Giarola, "A review of the theory, characteristics, and operation of frequency selective limiters," *IEEE Proceedings Microwave Theory & Tech.*, vol. 67, pp. 1380-1396, 1979.
- [4] C. Rauscher, "A Channelized-Limiter Approach to Receiver Front-End Protection," *IEEE Trans. MTT*, vol. 44, no. 7, pp. 1125-1129, 1996.
- [5] D.R. Jachowski, "Passive Enhancement of Resonator Q in Microwave Notch Filters," *IEEE MTT-S Int. Microwave Symp. Dig.*, vol. 3, pp. 1315-1318, 2004.
- [6] A.C. Guyette, I.C. Hunter, R.D. Pollard, D.R. Jachowski, "Perfectly-Matched Bandstop Filter using Lossy Resonators," *IEEE MTT-S Int. Microwave Symp. Dig.*, pp. 517-520, 2005.
- [7] P. Phudpong, I.C. Hunter, "Non Linear Bandstop Filters: A new Method of Frequency Selective Limiting," *Proceeding of 36th European Microwave Conference*, pp. 204-207, 2006.
- [8] J.D. Rhodes, "Microwave reflection filter including a ladder network of resonators having progressively smaller Q values," *United States Patent 5,781,084*, July 1998.